

TRACK: \_\_\_\_\_  
 EVENT: \_\_\_\_\_  
 DRIVER: \_\_\_\_\_ DATE: \_\_\_\_\_  
 QUAL: \_\_\_\_\_ FINISH: \_\_\_\_\_

# PRO-2

## SC BUGGY SETUP SHEET

### FRONT PROTRAC SUSPENSION

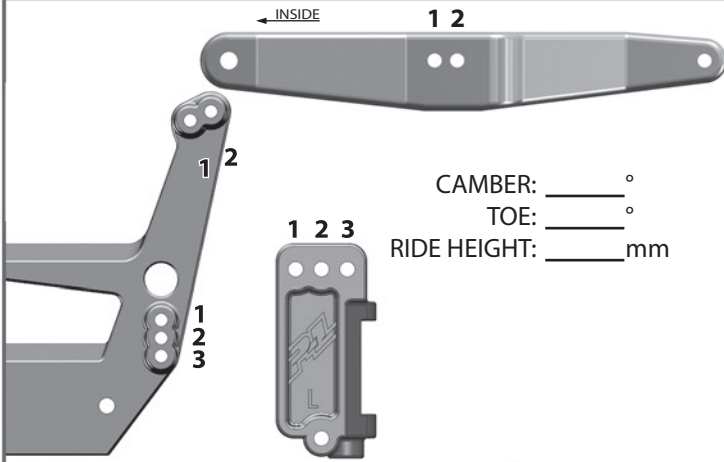

CAMBER: \_\_\_\_\_ °  
 TOE: \_\_\_\_\_ °  
 RIDE HEIGHT: \_\_\_\_\_ mm

### REAR PROTRAC SUSPENSION

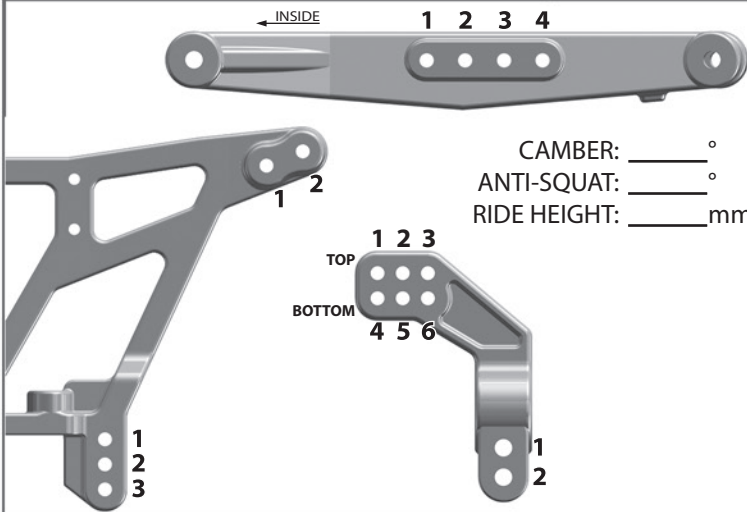

CAMBER: \_\_\_\_\_ °  
 ANTI-SQUAT: \_\_\_\_\_ °  
 RIDE HEIGHT: \_\_\_\_\_ mm

### ELECTRONICS

MOTOR: \_\_\_\_\_  
 ESC: \_\_\_\_\_  
 RECEIVER: \_\_\_\_\_  
 SERVO: \_\_\_\_\_  
 RADIO: \_\_\_\_\_

### TRACK INFORMATION

TRACTION:	HIGH	MED	LOW
SURFACE:	SMOOTH	BUMPY	BLUE GROOVE
CONDITIONS:	SOFT DIRT	CLAY	WET DUSTY

OTHER: \_\_\_\_\_

### FRONT TIRES

TIRE: \_\_\_\_\_  
 COMPOUND: \_\_\_\_\_  
 INSERT: \_\_\_\_\_  
 WHEEL: \_\_\_\_\_

### REAR TIRES

TIRE: \_\_\_\_\_  
 COMPOUND: \_\_\_\_\_  
 INSERT: \_\_\_\_\_  
 WHEEL: \_\_\_\_\_

### POWERSTROKE FRONT SHOCKS

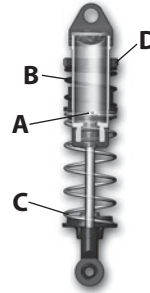

(A) PISTON: \_\_\_\_\_  
 OIL WEIGHT: \_\_\_\_\_  
 (B) PRIMARY SPRING: \_\_\_\_\_  
 (C) SECONDARY SPRING: \_\_\_\_\_  
 DROOP SPACER: \_\_\_\_\_ mm  
 COMPRESSION SPACER: \_\_\_\_\_ mm  
 (D) SPRING ADJUSTMENT: \_\_\_\_\_ mm

### POWERSTROKE REAR SHOCKS

(A) PISTON: \_\_\_\_\_  
 OIL WEIGHT: \_\_\_\_\_  
 (B) PRIMARY SPRING: \_\_\_\_\_  
 (C) SECONDARY SPRING: \_\_\_\_\_  
 DROOP SPACER: \_\_\_\_\_ mm  
 COMPRESSION SPACER: \_\_\_\_\_ mm  
 (D) SPRING ADJUSTMENT: \_\_\_\_\_ mm

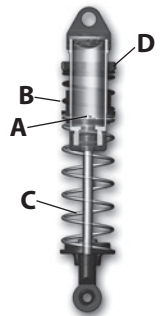

### BATTERY PLACEMENT

BATTERY: \_\_\_\_\_  
 PLACEMENT: \_\_\_\_\_

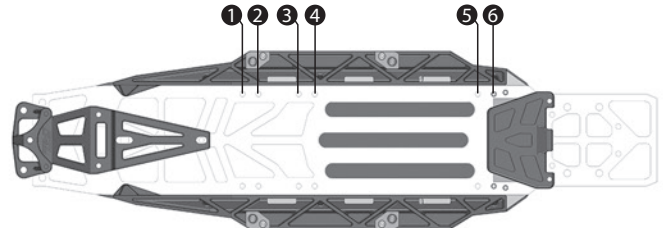

### TRANSMISSION SETTINGS

PINION: \_\_\_\_\_  
 SPUR GEAR: \_\_\_\_\_  
 DIFF. OIL: \_\_\_\_\_

### NOTES

\_\_\_\_\_  
 \_\_\_\_\_  
 \_\_\_\_\_  
 \_\_\_\_\_  
 \_\_\_\_\_